

400 series Pump head only

Drawing, for full details please see appropriate specification sheet (last updated Sep 2010)



The 400 range of peristaltic pumps has been designed to offer the OEM a low cost means of dosing a wide range of liquids at high volumes (750 - 7500+ ml/min). As with all peristaltic pumps they have excellent suction performance with the ability to self-prime to 5 metres, even when priming from dry. Peristaltic pumps offer a good level of accuracy and repeatability and as only the tube contacts the pumped media, they are corrosion resistant, extremely reliable, easy to clean and inexpensive to maintain. The range of stock motors to fit the 400 series pump heads gives a good choice of performance and is adaptable to many existing installations. For volume applications a wide range of speeds, voltages and special mounting brackets are available. In addition to the intermittent duty DC or AC configurations the Williamson Manufacturing Company Ltd can now offer customers continuous duty industrial pumps with an induction motor (with a choice of 115v or 230v single-phase or 400v 3-phase induction motor and optional speed controller). For more demanding applications we have now developed an optional upgraded roller assembly for use on the 400 series pumps. Rollers rotate on long life industrial Bal Bearings and the rotor cage is manufactured from stainless steel. To upgrade to the BB roller assembly simply add the suffix 'BB' to the model number of the pump.

The easiest way to place an order or check prices is via our online shop at <http://www.williamson-shop.co.uk> but please contact us for any requirements not listed or to place an order over the phone.

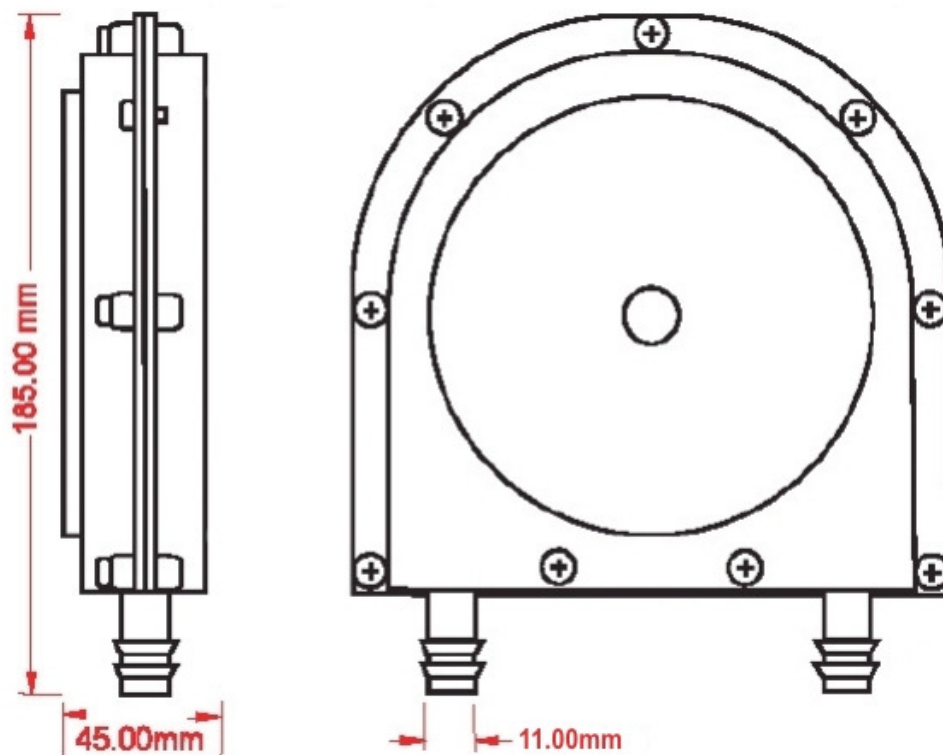

STANDARD CONNECTORS TO SUIT 12.5mm OR 1/2" I.D TUBE, SMOOTH BORE OPTION AVAILABLE FOR 19mm I.D FLEXIBLE TUBE.

The Williamson Manufacturing Company Ltd provides no warranty on usage of pumps. We recommend that life tests be carried out prior to use. This information is given in good faith and believed to be correct and current at time of publishing. The Williamson Manufacturing Company Ltd cannot accept responsibility for its inaccuracy or any errors or omissions contained herein. Copyright The Williamson Manufacturing Company Ltd 2008