

150 series DC powered oem Peristaltic pumps

Specification Sheet 1 (last updated May 2019)

- Easy tube change
- Continuous or fixed tube length
- Accurate dispense
- 3 (standard) or 6 (optional) roller system
- Planetary gearbox (no gearbox on Stepper models)
- Integrated positional encoder (optional)
- Choice of 3 different tube diameters
- Suitable for continuous operation
- Panel mounting
- No lubrication—no service
- Self priming



DC Motor: 12V /24V DC
Current at full speed250mA
Max ambient operational temperature 50°C
Material wetted partsLagoprene, PHI or Silicone
Port connectors (optional)for IDØ2.0mm tubing
Max pressure1 bar

Weight 125g
Life expectancy >1000 hours
Optional back shaft motor encoder 160 pulses per rotor rev
ID Ø1.0mm tubeup to 12ml/min
ID Ø2.0mm tubeup to 40ml/min
ID Ø3.0mm tube up to 90 ml/min

Choice of various tube sizes in Silicone, Lagoprene & PHI. Continuous tubing and fitted version available. Standard gear box ratio is 1:22.5, 245rpm @ 12V DC. Alternative gear box ratios available upon request subject to order quantities. Encoder shafts & encoders available on request.

Pumps supplied without tube, tube clamps or tube connectors

150-245-012-3	Pump 12VDC 260RPM 3 rollers w/o tubing
150-520-024-3	Pump 12VDC 260RPM 3 rollers w/o tubing
150-800-012-3	Pump Stepper motor 3 rollers w/o tubing

150-245-012-6	Pump 12VDC 260RPM 6 rollers w/o tubing
150-520-024-6	Pump 12VDC 260RPM 6 rollers w/o tubing
150-800-012-6	Pump Stepper motor 6 rollers w/o tubing

Pumps supplied with Silicone tubing, tube clamps and tube connectors

150-245-012-201-3	Pump 12VDC 260RPM 3 rollers 1mm sil
150-245-012-201-6	Pump 12VDC 260RPM 6 rollers 1mm sil
150-800-012-201-3	Pump Stepper motor 3 rollers 1mm sil

Williamson Manufacturing Company Ltd

Unit 2, Centenary Industrial Estate, Hughes Road, Brighton, BN2 4AW, UK. Tel +44(0)1273 857752

E Mail:- sales@williamsonpumps.co.uk Web www.wmcpumps.com

150-800-012-201-6	Pump Stepper motor 6 rollers 1mm sil
150-245-012-202-3	Pump 12VDC 260RPM 3 rollers 2mm sil
150-245-012-202-6	Pump 12VDC 260RPM 6 rollers 2mm sil
150-800-012-202-3	Pump Stepper motor 3 rollers 2mm sil
150-800-012-202-6	Pump Stepper motor 6 rollers 2mm sil
150-245-012-203-3	Pump 12VDC 260RPM 3 rollers 3mm sil
150-245-012-203-6	Pump 12VDC 260RPM 6 rollers 3mm sil
150-800-012-203-3	Pump Stepper motor 3 rollers 3mm Sil
150-800-012-203-6	Pump Stepper motor 6 rollers 3mm Sil

Pumps supplied with Lagoprene tubing, tube clamps and tube connectors

151-245-012-202-3	Pump 12VDC 260RPM 3 rollers 2mm sant
151-245-012-202-6	Pump 12VDC 260RPM 6 rollers 2mm sant
151-800-012-202-3	Pump Stepper motor 3 rollers 3mm food sant
151-800-012-202-6	Pump Stepper motor 6 rollers 3mm food sant

Pumps supplied with PHI tubing, tube clamps and tube connectors

153-245-012-201-3	Pump 12VDC 260RPM 3 rollers 1mm PHI
153-245-012-201-6	Pump 12VDC 260RPM 6 rollers 1mm PHI
153-800-012-201-3	Pump Stepper motor 3 rollers 1mm PHI
153-800-012-201-6	Pump Stepper motor 6 rollers 1mm PHI

Silicone tube Set (75mm long) with pp connector

150-01-01	Silicone tube (plat cured) 1mm ID x 1mm WT N420/410
150-02-01	Silicone tube (plat cured) 2mm ID x 1mm WT N220-6
150-03-01	Silicone tube (plat cured) 3mm ID x 1mm WT N230-6

Lagoprene tube Set (75mm long) with pp connector

151-02-01	Lagoprene tubing 2mm ID x 1mm WT N220
151-03-01	Lagoprene tubing 3mm ID x 1mm WT N230

PHI tube Set (75mm long) with pp connector

153-01-01	Pharmed tubing 1mm ID x 1mm WT N420/410
-----------	---

Tube Clamp (for use with continuous tube)

Williamson Manufacturing Company Ltd

Unit 2, Centenary Industrial Estate, Hughes Road, Brighton, BN2 4AW, UK. Tel +44(0)1273 857752

E Mail:- sales@williamsonpumps.co.uk Web www.wmcpumps.com

150-TC-01	Tube clamp for 1mm tube (two required per pump)
150-TC-02	Tube clamp for 2mm tube (two required per pump)
150-TC-03	Tube clamp for 2mm tube (two required per pump)

Silicone tubing (per metre)

150-01-01-1M	Silicone tubing 1mm ID x 1mm WT per metre
150-02-01-1M	Silicone tubing 2mm ID x 1mm WT per metre
150-03-01-1M	Silicone tubing 3mm ID x 1mm WT per metre

Lagoprene tubing (per metre)

151-02-01-1M	Santoprene tubing 2mm ID x 1mm WT per metre
151-03-01-1M	Norprene tubing 3mm ID x 1mm WT per metre

PHI tubing (per metre)

153-01-01-1M	Phar Med tubing 1mm ID x 1mm WT per metre
--------------	---

Hose Connectors (as used in tube sets)

Micro 1	1mm barbed connector pp N420/410 pair
Micro 2	2mm barbed connector pp N220-6 pair
Micro 3	3mm barbed connector pp N230-6 pair

The easiest way to place an order or check prices is via our online shop at <http://www.williamson-shop.co.uk> but please contact us for any requirements not listed or to place an order over the phone.

Tube data:-

Silicone	Premium silicone tube for food and biomedical applications. Suitable for sterilization via autoclave or dry heat. FDA registered.
Lagoprene	Food grade thermoplastic elastomer for food and beverage applications. Complies with NSF 51 (food equipment materials)
PHI	Premium medical grade thermoplastic elastomer for pharmaceutical, biological and food / beverage applications. Suitable for sterilization via autoclave, ethylene oxide and gamma. FDA registered to 21CFR177.2600

Stepper Motor Drawing:-

Williamson Manufacturing Company Ltd

Unit 2, Centenary Industrial Estate, Hughes Road, Brighton, BN2 4AW, UK. Tel +44(0)1273 857752

E Mail:- sales@williamsonpumps.co.uk Web www.wmcpumps.com

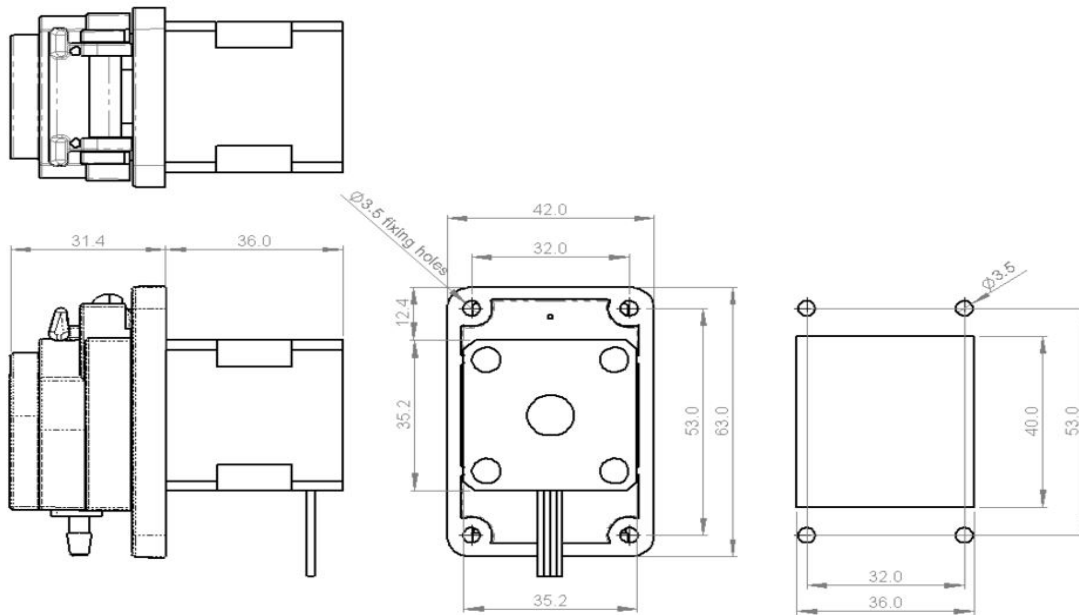

Stepper Motor Technical data:-

HIGH TORQUE HYBRID STEPPING MOTOR SPECIFICATIONS			
General specifications		Electrical specifications	
Step Angle (°)	1.8	Rated Voltage (V)	2.7
Temperature Rise (°C)	80 Max (rated current, 2 phase on)	Rated Current (A)	1.0
Ambient temperature (°C)	-20~+50		± 2.7 (25°C)
Number of Phase	2		± 4.3
Insulation Resistance	100MΩ, Min (500VDC)	Holding Torque (Kg.cm)	1.4
Insulation Class	Class B	Detent Torque (g.cm)	100
Max.radial force (N)	28 (20mm from the flange)	Rotor Inertia (g.cm ²)	14
Max.axial force (N)	10	Weight (Kg)	0.18

● VOLTAGE: 24VDC, CONSTANT CURRENT: 1.0A, HALF STEP

● Wiring Diagram:

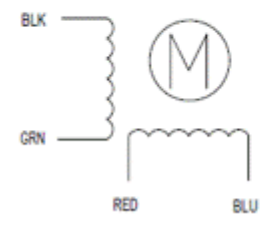
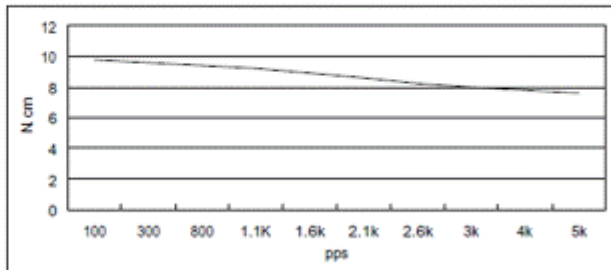



DC Motor drawing:-

Williamson Manufacturing Company Ltd

Unit 2, Centenary Industrial Estate, Hughes Road, Brighton, BN2 4AW, UK. Tel +44(0)1273 857752

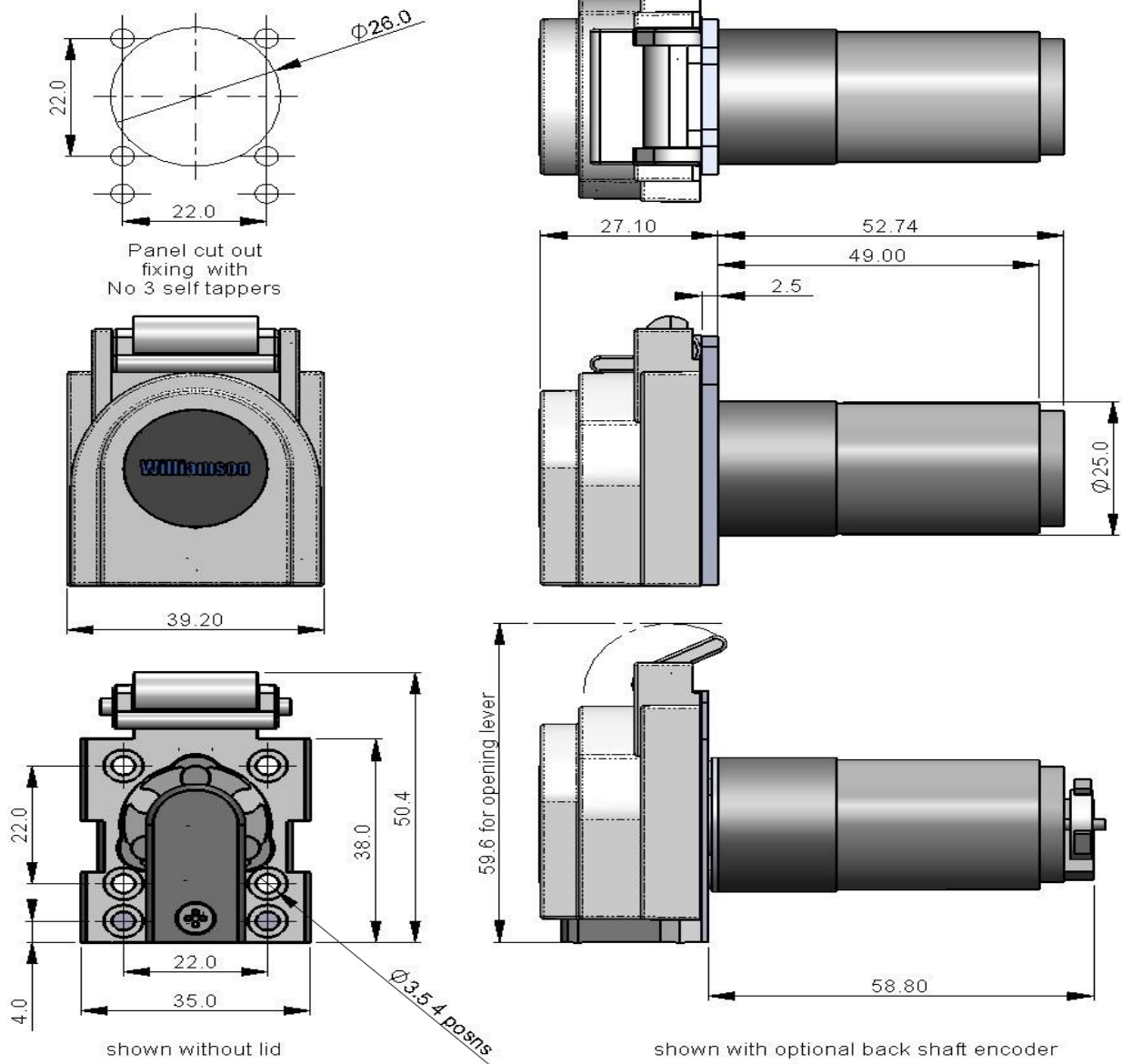
E Mail:- sales@williamsonpumps.co.uk Web www.wmcpumps.com



Williamson Manufacturing Company Ltd

Unit 2, Centenary Industrial Estate, Hughes Road, Brighton, BN2 4AW, UK. Tel +44(0)1273 857752

E Mail:- sales@williamsonpumps.co.uk Web www.wmcpumps.com