

300 series Peristaltic Pump with Stepper Motor



- Extremely long life
- Very wide speed control range
- Quiet operation
- Easy tube replacement
- Self priming to 3 metres
- Flow to 800ml per minute

As with all peristaltic pumps the 300 series cased has excellent suction performance, are self-priming up to 3m from dry and capable of pumping up to 12m head pressure. Peristaltic pumps offer a good level of accuracy and repeatability and as only the tube & tube fittings contact the pumped media, they are corrosion resistant, easy to clean, extremely reliable and inexpensive to maintain.

The standard tube fittings for 5 and 6mm ID tube are nylon but a special chemical resistant version (PP after part number) is also available that uses polypropylene fittings (standard on the 3mm).

Additionally the 300 series of pumps offer extremely long tube life because of their low friction needle bearing rollers and unique tube cantering roller cage. Coupled to this the brushless motors are built with ball bearings throughout which also offers exceptional longevity.

The pump is available with or without the driver electronics. The optional driver/controller is available as an "SMA" type complete with on board miniature speed potentiometer (suitable for calibration or very infrequent changes of speed) or a "SMB" type. The "SMB" type requires an external (customer supplied) 10KΩ potentiometer or 0-5v signal for speed control. In both cases the driver is self pulsing so the motor will run when connected to a standard DC supply at any voltage from 12 to 30v (24-30v for Santoprene, Viton® or Norprene Chemical®).

Dimensions (mm)

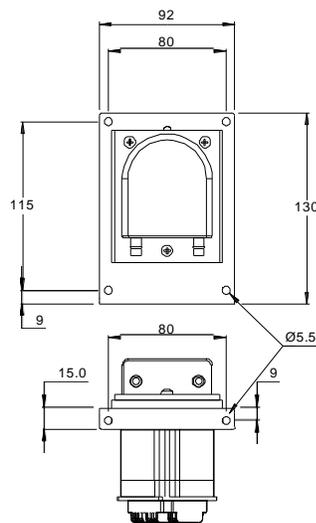

Weight:
Approx. 1.2Kg

Specifications

Flow

Tube Size	Silicone Tube	Santoprene	Viton®	Norprene Chemical®
3	1.1ml/rev	1ml/rev	0.8ml/rev	0.9ml/rev
5	2.2ml/rev	2ml/rev	1.6ml/rev	1.8ml/rev
6	3.2ml/rev	3ml/rev	2.4ml/rev	2.8ml/rev

Note: Above figures are based on pumping water and are for guidance only. Flow rate is subject to tube tolerance, tube age, back pressure and fluid viscosity.

Motor

Materials of Construction	
Pump Body & cover	Polypropylene
Rotor	Aluminium (plated)
Needle bearing rollers	Stainless steel
Inlet/outlet moulding	10% glass filled polycarbonate
Bracket	Stainless Steel

Specification	Units	Value
Step angle	°	1.8
Phase current	A	1.4
Phase resistance	Ω	3.1
Phase inductance	mH	11
Mass	Kg	0.6

The Williamson Manufacturing Company Ltd provides no warranty on usage of pumps. We recommend that life tests be carried out prior to use. This information is given in good faith and believed to be correct at the time of publishing. The Williamson Manufacturing Company Ltd cannot accept responsibility for inaccuracy or any errors contained herein. Copyright the Williamson Manufacturing Company Ltd 2008.



Williamson Manufacturing Co Ltd
Unit 2, Centenary Industrial Estate
Hughes Road
Brighton
East Sussex BN2 4AW UK
Email: sales@williamsonpumps.co.uk

300 series Peristaltic Pump with Stepper Motor

Connections

Motor only

Bipolar drive-parallel	Wire Colours (scheme 1)	Wire Colours (scheme 2)
A+	White/Black wire + Orange wire	Red + Blue
A-	White/Orange wire + Black wire	Yellow + Black
B+	White/Red wire + Yellow wire	White + Brown
B-	White/yellow wire + Red wire	Orange + Green

SMB Type driver

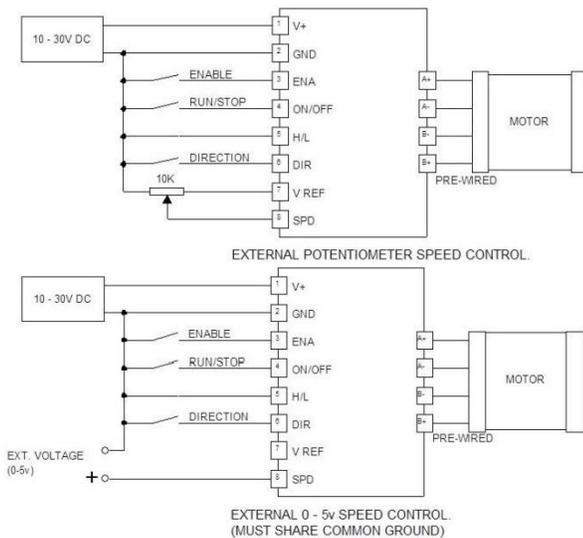

SMA Type driver

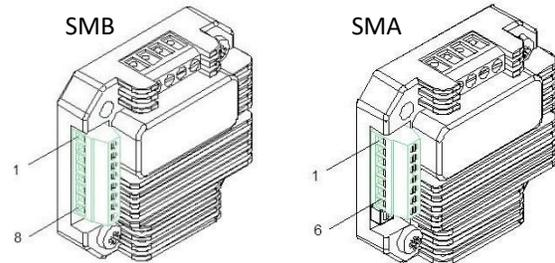
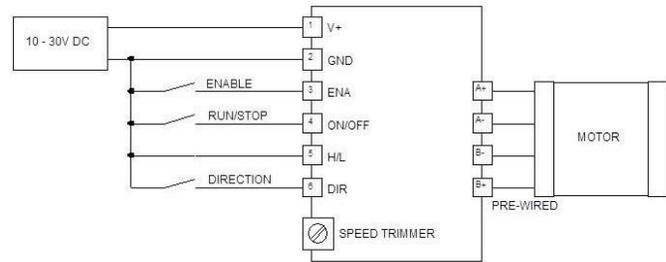

H/L must be connected to 0v for 40 & 150 rpm speed ranges. ENA, On/Off & Direction connections are optional. Pump will run clockwise once supply is connected remove to stop or alternatively connect 0v to ENA this will stop motor. Connecting 0v to ON/OFF will also stop the motor but it is a powered stop/hold so motor will remain powered all the time causing additional heat generation. Please call the office if you have any connection queries as incorrect connection could cause damage to the driver.

Part Numbers

NOTE: ACTUAL 0-5V SPEED CONTROL RANGE IS 0.5- 4.5V

DEVISE YOUR PRODUCT CODE USING THE PRODUCT CODES FROM THE TABLE (RIGHT) WHERE STATED BELOW. (PLEASE NOTE EXCLUSIONS LISTED IN TABLE).

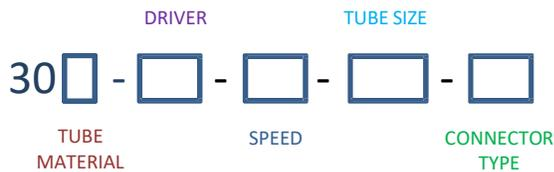

FOR EXAMPLE AN 300 SERIES WITH STEPPER MOTOR, SILICONE TUBE, SMB DRIVER, 150 RPM, WITH 5mm ID TUBE & POLYPROPYLENE CONNECTORS WOULD BE:

300-SMB-150-050-PP

OPTIONS	PRODUCT CODE
TUBEMATERIAL SILICONE SANTOPRENE VITON® (3 & 5mm TUBE ONLY) NORPRENE CHEMICAL®	0 1 2 7
DRIVER TYPE SMA SMB NO DRIVER	SMA SMB SM
SPEED 40 RPM 150 RPM 250 RPM	040 150 250
TUBE SIZE 3.2mm ID (PP CONNECTOR ONLY) 4.8mm ID 6.4mm ID (NOT AVAILABLE IN VITON)	030 050 060
CONNECTOR TYPE POLYPROPYLENE STANDARD (NOT 3MM TUBE)	PP NO CODE

The Williamson Manufacturing Company Ltd provides no warranty on usage of pumps. We recommend that life tests be carried out prior to use. This information is given in good faith and believed to be correct at the time of publishing. The Williamson Manufacturing Company Ltd cannot accept responsibility for inaccuracy or any errors contained herein. Copyright the Williamson Manufacturing Company Ltd 2008.



Williamson Manufacturing Co Ltd
Unit 2, Centenary Industrial Estate
Hughes Road
Brighton
East Sussex BN2 4AW UK
Email: sales@williamsonpumps.co.uk