

October 2020



- 32 Programmable individual or every day dose times.
- Battery or mains operated options.
- Highly visible blue back lit display.
- Compact IP55 Casing.

Developed for timed dosing of various applications including drain & grease traps, urinals and water treatment. The dosing pump utilises an easy to use custom programmable control unit & our standard 200 series pump head. The unit includes features such as: Battery status indication, voltage drop compensation (for stable pump output), flow calibration, battery back up & the option to pass code protect settings. The battery back up is only required to retain the time and day, all program settings are retained even if the power and back up batteries are absent. The LDS4.01B utilises a battery pack rather than individual batteries for proven reliability. The IP55 case is custom moulded in ABS, has a small footprint and is wall mountable.

General specifications:

- Pump output approximately 40 ml/min*.
- Battery life of over 1 year based on normal drain dosing usage*.
- Battery back up life approximately 40 hours (not re-chargeable).
- 5mm tube connectors.
- Comes complete with 5 meters of pvc suction & discharge hose, tube stiffener, stiffener retaining clip, wall plugs, woodscrews for wall mounting and back up battery.

* Approximately

The Williamson Manufacturing Company Ltd provides no warranty on usage of pumps. We recommend that life tests be carried out prior to use. This information is given in good faith and believed to be correct at the time of publishing. The Williamson Manufacturing Company Ltd cannot accept responsibility for inaccuracy or any errors contained herein. Copyright the Williamson Manufacturing Company Ltd 2008.



Williamson Manufacturing Co Ltd
Unit 5 Lady Bee Industrial Estate
Southwick
West Sussex BN42 4EP
UK
Email: sales@wmc pumps.co.uk

October 2020

Order Code	Description
LDS4.01B	Battery powered dosing pump complete with battery pack. Shipping weight 1.6Kg
LDS4.01M	Mains powered dosing pump complete with plug in PSU including UK,EU and USA AC heads. Shipping weight 1.0Kg
LDS4.01M-WM	Mains powered dosing pump complete with wall mount power supply. Shipping weight 1.0Kg
LDS4.01M-INT	Mains powered dosing pump complete with internal PSU and mains lead for connection to fused spur. Shipping weight 1.0Kg
LDS4.01-BATT-PACK	Spare battery pack . Shipping weight 0.6Kg

Dimensions (mm):

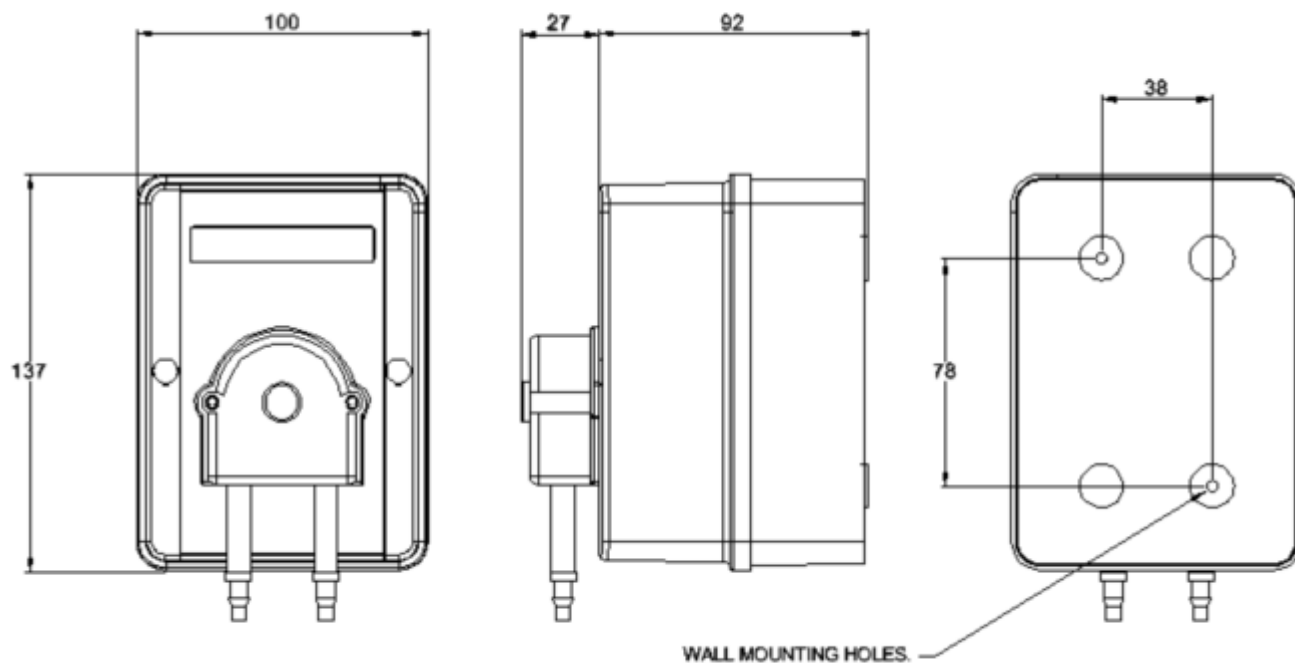

The Williamson Manufacturing Company Ltd provides no warranty on usage of pumps. We recommend that life tests be carried out prior to use. This information is given in good faith and believed to be correct at the time of publishing. The Williamson Manufacturing Company Ltd cannot accept responsibility for inaccuracy or any errors contained herein. Copyright the Williamson Manufacturing Company Ltd 2008.



Williamson Manufacturing Co Ltd
 Unit 5 Lady Bee Industrial Estate
 Southwick
 West Sussex BN42 4EP
 UK
 Email: sales@wmcumps.co.uk