

**For further information or for spares  
please contact your local dealer:**

# **200CM PERISTALTIC PUMP**

**70 rpm 230V AC**

## **Operator Guide**

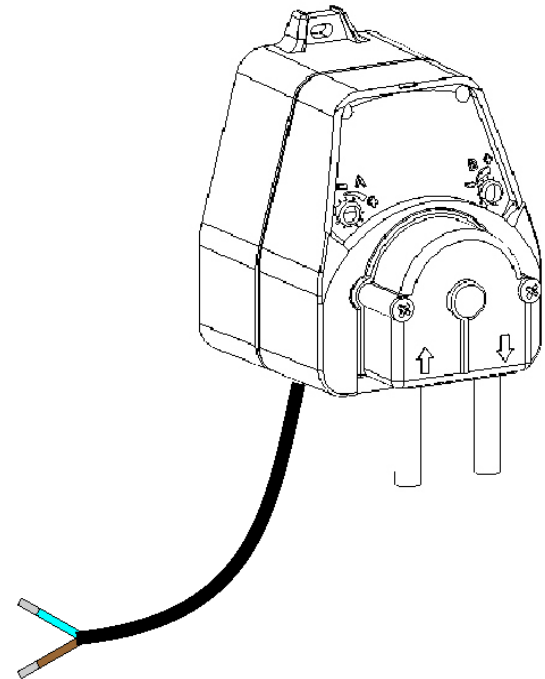

**Important Safety Precautions:**

Please read the following precautions carefully before using this equipment. This 200CM unit contains high voltage circuits that may expose you to the danger of electric shock.

- After un-packing check product for damage & reject if found.
- Not for use in life support, nuclear or other high risk applications where failure of the system could reasonably be expected to cause a hazard.
- Do not mount the unit to unstable, irregular or non-vertical services.
- Do not place heavy objects on top of the unit.
- Do not attempt to place items (such as screwdrivers) into the moving parts of the pump head.
- Do not power the unit outside of the values stated on the rating label.
- Do not use if cables, case or tubing are damaged.
- Do not dismantle or modify this equipment.
- Do not replace pump head screws with anything other than plastic to maintain Class II.
- Always ensure that care is taken when handling chemicals.
- Always take care to avoid kinking of suction or delivery tubes.
- CAUTION: it is the responsibility of the user to ensure that the peristaltic tubes are compatible with the intended products.**

**Operation:**

This 200CM dispenser provides an accurate dose of one product. The unit is variable speed and also incorporates the option of a cyclic operation to further control product dosing.

**Installation:**

Should the supply cord become damaged, it should be replaced by the manufacturer or its service agent or a similarly qualified person in order to avoid a hazard. When mounting unit do not over-tighten fixing screws. The supply to the unit should be fused at 3A maximum. The unit has been tested for EMC immunity to expected levels, If higher levels are experienced causing system malfunctions move unit away from source. When dosing rinse-aid or in other applications where the pump is dosing into a pressurised system, there is a maximum pressure of 2 bar against which the pump can operate satisfactorily. Do not exceed 2 bar pressure at any time.

Beneath the front cover of the 200CM are two potentiometers.

**Potentiometer B – used to adjust the Pump Speed:**

Adjust Potentiometer B clockwise or anti-clockwise using a screwdriver to increase / decrease flow speed. Setting Potentiometer A to max. will ensure continuous operation at the chosen speed.



**Potentiometer A – used to adjust the Cyclic OFF period (0 – 3 seconds).**

**NOTE: The dose cycles every 3 seconds so the dose time can be set from zero to 100%.**

For cyclic operation potentiometer A must be set above zero. Adjust potentiometer A using a screwdriver to vary the OFF time duration. Adjust speed using potentiometer B.

**Specification:**

**POWER SUPPLY:** 230vAC  
50Hz – 60Hz Class II  
20mA  
5 W

**INTERNAL FUSING:** T 500mA on Live (brown) connection.  
Fuse should be replaced with fuse of same type & rating only.

**MOTOR:** 18vDC

**MAXIMUM FLOW RATES:** For guidance only . Subject to tube, motor tolerances, temperature, viscosity & back pressure

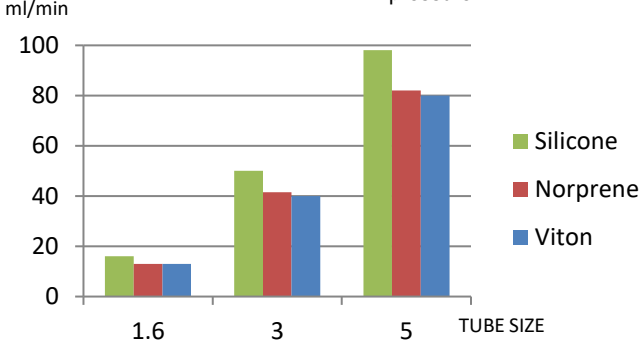

**ENCLOSURE:** ABS – IP55  
**WEIGHT:** 0.85Kg Approx.  
**APPROVALS:** CE

